

Note Injector Numbers are in firing order not cylinder number

See attached notes.

All 5 volt and Sensor Gnd connections are equivalent (except Lambda Gnd). Use the ones which are most suitable for the sensors connected. If not using twisted pair wire, twist together separate wires especially the sensor connections with a pitch of approx. 2.5 cm

**Crank sensor connections**

Use twisted pair wire with overall screen for crank sensor

VR sensor pin outs (magnetic)

Ford  
Pin 1 to pin 8  
Pin 2 to pin 47  
Shield to pin 47 at ECU

Vauxhall/Opel/BMW/Volvo/Saab/etc. (Bosch & Siemens)  
Pin 1 to pin 8  
Pin 2 to pin 47  
Pin 3 to shield to pin 47 at ECU

Marelli  
Pin 2 to pin 8  
Pin 1 to pin 47  
Shield to pin 47 at ECU



Tel +44 (0)161 877 1419  
Fax +44 (0)161 877 7086  
Email office@dtafast.co.uk

WIRING SCHEMATIC  
FOR  
P8PRO V29.0 FIRMWARE OR LATER  
LAST UPDATED 01/10/2002  
\*\* SEE ATTACHED NOTES \*\*

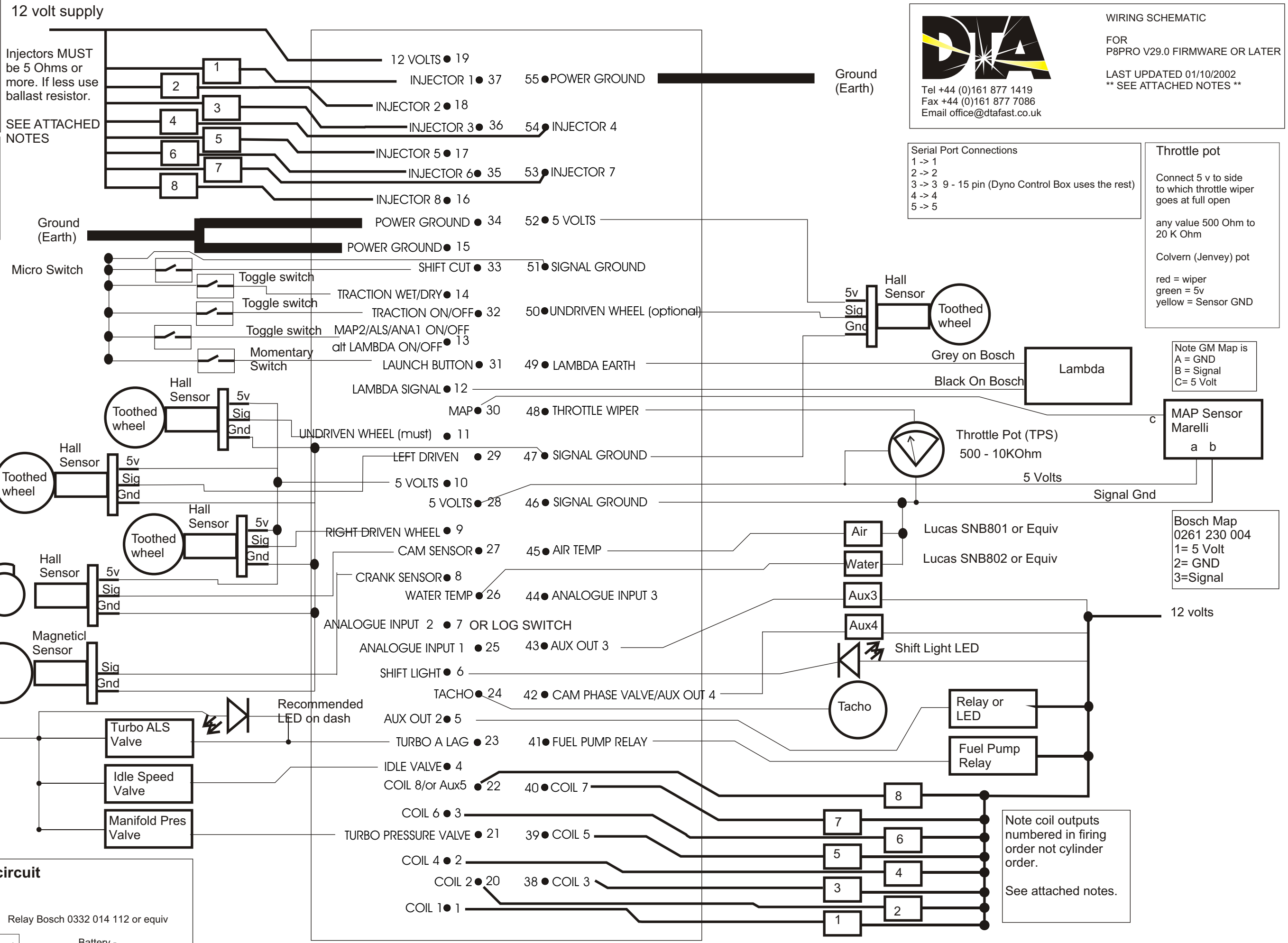

**Serial Port Connections**

1 -> 1  
2 -> 2  
3 -> 3 9 - 15 pin (Dyno Control Box uses the rest)  
4 -> 4  
5 -> 5

**Throttle pot**

Connect 5 v to side to which throttle wiper goes at full open

any value 500 Ohm to 20 K Ohm

Colvern (Jenvey) pot

red = wiper  
green = 5v  
yellow = Sensor GND

Note GM Map is  
A = GND  
B = Signal  
C = 5 Volt

**MAP Sensor Marelli**

a b c

**Bosch Map 0261 230 004**

1= 5 Volt  
2= GND  
3=Signal

Note coil outputs numbered in firing order not cylinder order.

See attached notes.

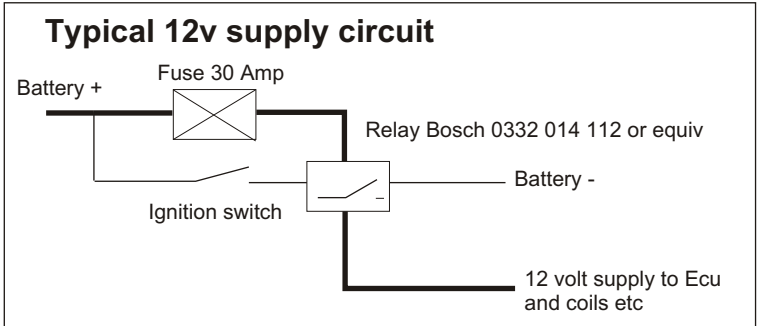

Latch end

## Injector Wiring

**Note all injectors must be high impedance types or use a ballast resistor.**

### Sequential

Remember that the outputs are numbered in firing sequence, that is 1 is the first to fire, 2 the second etc. For a 4 cylinder with a firing sequence of 1/3/4/2 connect wires as below.

Cyl	1	3	4	2
O/P	1	2	3	4

And similarly for 6 or 8 cylinder engines. 8 cylinders is the maximum that can be handled with sequential injection. A cam sensor MUST be fitted for sequential injection.

### Non Sequential

Use O/P's 1,2 and 5,6. Balance numbers of injectors on each

### Non Sequential Twin Injector

Injectors 1:- Use O/P's 1,2 and 5,6. Balance numbers of injectors on each

Injectors 2:- Use O/P's 3,4 and 7,8. Balance numbers of injectors on each

## Coil Wiring

### Coil Per Plug

Remember that the outputs are numbered in firing sequence, that is 1 is the first to fire, 2 the second etc. For a 4 cylinder with a firing sequence of 1/3/4/2 connect wires as below. A cam sensor MUST be fitted for coil per plug operation.

Cyl	1	3	4	2
O/P	1	2	3	4

And similarly for 6 or 8 cylinder engines.

### Wasted Spark

Use the lowest outputs. For a 6 cylinder engine with a firing order of 1/3/6/4/5/2 wire as below.

Cyl	1	3	6
Cyl	4	5	2
O/P	1	2	3

### Distributor

Use Coil output 1 or 2..

### Twin Spark

Coil O/P's 1 to 4 work as normal. Coil O/P's 5 to 8 are the matching second plug. For a 4 cylinder, coil per plug, twin spark wire as below.

Cyl	1	3	4	2	First Plug
O/P	1	2	3	4	
Cyl	1	3	4	2	Second Plug
O/P	5	6	7	8	

Four cylinder coil per plug or 8 cylinder wasted spark is the maximum for twin spark operation.

WIRING NOTES



Tel +44 (0)1274 667960  
Fax +44 (0)1274 663627  
Email office@dtafast.demon.co.uk

FOR  
P8PRO V29.0 FIRMWARE OR LATER

LAST UPDATED 01/10/2002

## ANALOGUE 2 WIRING FOR LOG SWITCH

If using the analogue 2 input for switching the log on and off use the following wiring.

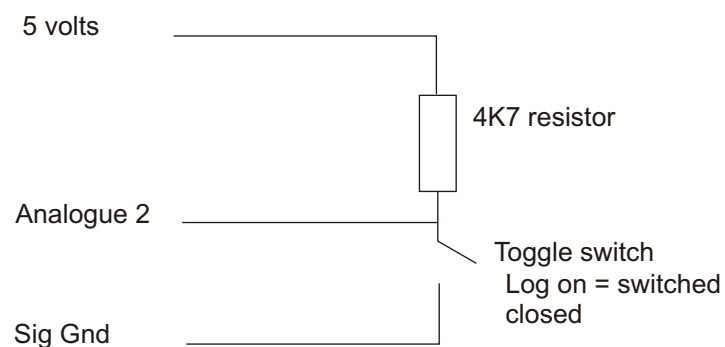

## Special Considerations for Audi 5 Cylinder

The engine must have 5 coils and a 60 - 2 crank wheel at 60 degrees. Set to 10 cylinders in general engine settings. Set unequal firing and 1 coil per plug OFF in unequal firing angles. Set sequential injection OFF in injector phasing. You do not need a cam sensor.

### Wire coils as below

Cyl	1	5	2	3	4
O/P	1	2	3	4	5

### Wire Injectors as below

Cyl	1	5	2	3	4
O/P	1	2	5	6	6